

wall-mounted
with hose reel



Art. 45110

Art. 45110 Fixed suction drainer with pump
Composed of: pump equipped with vacuum gauge
suction hose reel with hose 10 m x 1/2"
4 m draining hose, series of probes (art. 45560)
plus probe ø 12 (art. 45540)

N° 2 packing m^3 0,116 kg 29,1

Article	45110
Pump suction ratio 1:1	33060
Max. pressure air to pump	6 bar
Noise level	81 dB
Max. air consumption	130 l/min
Suction hose reel	1/2" x 10 m
Length draining hose	1/2"x 4 m
Suction speed with oil at 70-80°C, probes 6 mm.	1,5 - 2 lt/min

WARNING: Do not use flammable or corrosive liquids.

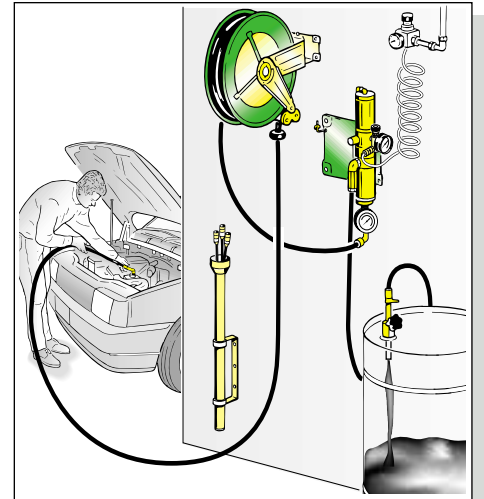
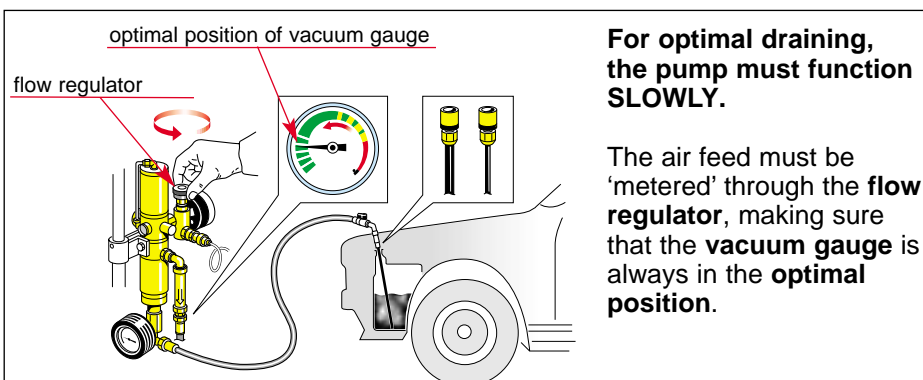

Fixed drainer with pump
The air-operated pump is equipped **with special teflon seals** making it suitable for draining various waste oils and antifreeze liquid from any vehicle or motorcycle. Very useful in mechanical workshops and body shops **Draining** occurs by means of a probe specially chosen from those supplied. The oil must be hot (70/80 °C).

Best use of the article is obtained by connecting to a fixed system enabling the liquid sucked to be discharged directly into the disposal tank.

INSTALLATION INSTRUCTIONS

