

FLOOR MOUNTED



Art. 42070 **50lt**

Art. 42070 Floor-mounted waste oil drainer for trucks, tank capacity 50 litres

N° 1 packing m^3 0,136 kg 18,8

Article	42070
Capacity	50 lt
Casters	4 x \varnothing 80
Discharge tube	incorporated

Warning: Do not use flammable or corrosive liquids.

Transfer of the drained oil can be done by suction with any suction unit, the suction probe, or else by conveying the oil to the tank by means of wall kit art.33125 situated on the fixed system.

Art. 33125 Wall kit for emptying tanks

see page 67

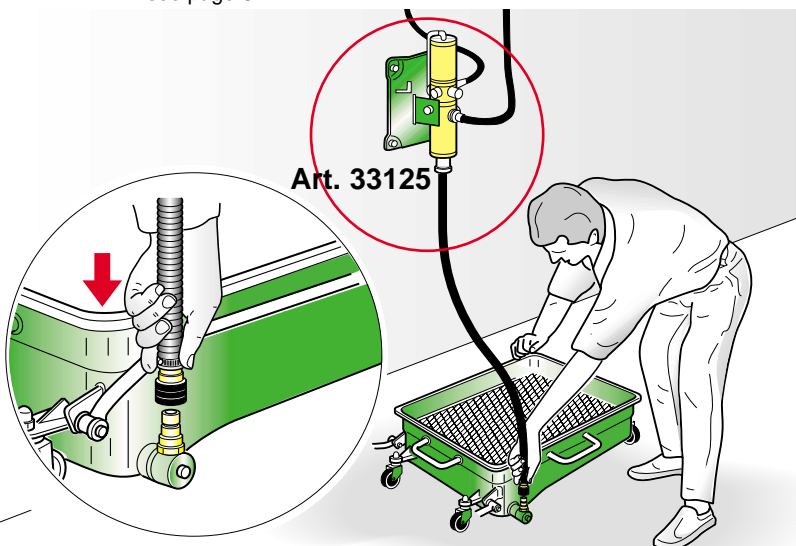

Possibility of applying connections (quick-connector art. 33126-33127) to connect the tank to a pump art. 33125.



Floor-mounted oil drainer, wheel-mounted, suitable for gravity draining of engine, gearbox and differential oil from all motor vehicles even if not placed on auto lift or pit.

The 50-litre capacity collection tank is equipped with an antispash screen which can also be used as a support.

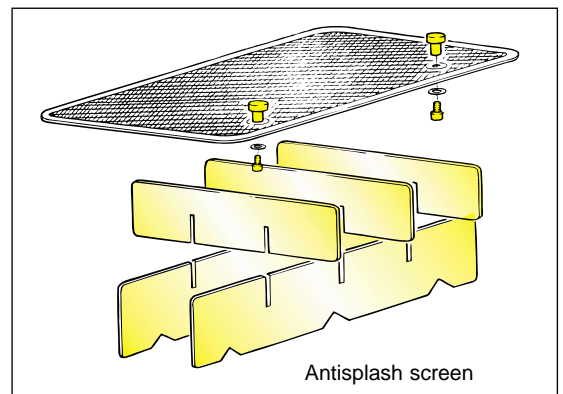

Overall dimensions

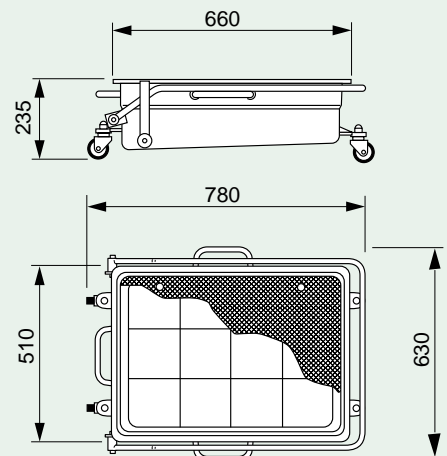

art. 42070